

# Low Voltage Switchgear

WS Series Molded Case Circuit Breakers .....	456
MCCB Operating Handles .....	458
Circuit Protectors .....	459
General Purpose Contactors .....	460
Motor Protection Relays .....	460
Definite Purpose Contactors .....	460
Contactor Relays.....	460
Vacuum Contactors .....	460

**Stock Product:** Stock product is product MEAU makes every effort to have on hand for immediate shipment. There may be instances when we are out of stock due to unexpected large requirements. All stock product will be indicated in this book by an “S” in the Stocked Item columns/rows.

**Non-Stock Product:** Non-stock product is product supplied on an “as-needed” basis. Standard lead times of 6 - 8 weeks apply, product is non-returnable and non-cancelable. Product listed as non-stock may change to stock product subject to increases in sales and usage. All non-stock product will be indicated in this book by a dash “-” in the Stocked Item columns/rows.

# WS Series Molded Case Circuit Breakers

The WS Series MCCB is designed to give UL 489 compliant circuit protection for panels and OEM equipment. Mitsubishi's new MCCB range includes sizes with continuous current ratings from 5A up to 600A - suitable for 230V, 480V or 600V operation.











### Main Features

- UL489 / CSA approved and tested for branch circuit protection
- Compact
- Reliable
- Cost-effective
- Suitable for Isolation duty
- Suitable for reverse connection
- Suitable for AC or DC operation
- TÜV and CCC type approved, GE marked throughout the range
- Fully RoHS compliant

### A full range of options and accessories is also supported:

- NEMA 12 interlocking handles including Emergency Stop types for NFPA79 requirements
- Auxiliary contacts
- Alarm switches
- Shunt trips
- Under-voltage trips
- Terminal covers
- Phase insulating barriers
- Choice of screw (std), bus bar, or "solderless" box terminals to facilitate installation

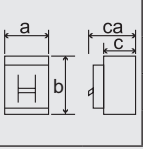
Frame A		100	225	50	100	150	250	400	600			
		NF100-CWU	NF225-CWU	NF50-SWU	NF100-SWU	NF-SFW	NF-SJW	NF-HJW	NF-SKW	NF-SLW		
Model												
Stocked Item		-	-	All 3 pole breakers	All 3 pole breakers	125 & 150 amp only	175, 200, 225, & 250 amp only	-	300, 350 & 400 amp only	500 & 600 amp only		
Rated Current in Amp. at Ambient Temperature 40°C (IEC 30°C)		50, 60, 75, 100	125, 150, 175, 200, 225	(3), 5, 10, 15, 20, 30, 40, 50	15, 20, 30, 40, 50, 60, 75, 100	15, 20, 30, 40, 50, 60, 70, 80, 90, 100, 110, 125, 150	(125), (150), 175, 200, 225, 250	125, 150, 175, 200, 225, 250	250, 300, 350, 400	500, 600		
Number of Poles		2   3	3	2   3	2   3	3	3	3	3	3		
Rated Short-Circuit Breaking Capacities (kA)	UL 489	Rated Voltage (VAC)	240	240	240	480Y/227	600Y/347	600Y/347	600Y/347	600Y/347	600Y/347	
		AC	600Y/347V	-	-	-	-	14	14	18	20	20
			480V	-	-	-	-	35	35	50	35	35
			480Y/277V	-	-	-	22	35	35	50	-	-
	240V	10	35	14	35	65	65	100	65	85		
	JIS C 8201-2 IEC 60947-2 (Icu/Ics)	AC	Rated Insulation Voltage Ui (V)	600	600	600	690	690	690	690	690	690
			690V	-	-	-	8/4	8/8	8/8	15/15	10/10 (5/5) (*5)	10/10
			500V	7.5/4	10/5	7.5/4	18/9	30/30	30/30	36/36	30/30 (25/25) (*5)	30/30
			440V	10/5	15/8	7.5/4	25/13	36/36	36/36	50/50	42/42 (36/36) (*5)	42/42
			415V	10/5	18/9	7.5/4	30/15	36/36	36/36	50/50	45/45 (36/36) (*5)	45/45
400V			10/5	18/9	7.5/4	30/15	36/36	36/36	50/50	45/45 (36/36) (*5)	45/45	
380V			10/5	18/9	7.5/4	30/15	36/36	36/36	50/50	50/50 (42/42) (*5)	50/50	
230V	30/15	35/18	15/8	50/25	85/85	85/85	100/100	85/85 (65/65) (*5)	85/85			
DC	250V (*3)	7.5/4	10/5	-	15/8	20/20	20/20	20/20	-	-		
Compatible to AC/DC (*1)		Yes	Yes	-	Yes	Yes	Yes	Yes	-	-		
Suitable for Isolation		Yes	Yes	Yes	Yes	Yes	Yes	Yes	Yes	Yes		
Reverse Connection		Yes	Yes	Yes	Yes	Yes	Yes	Yes	Yes	Yes		
Overall Dimensions mm (in)		a	60 (2.36)   90 (3.54)	105 (4.13)	50 (3.94)   75 (2.95)	60 (2.36)   90 (3.54)	105 (4.13)	105 (4.13)	105 (4.13)	140 (5.51)	210 (8.27)	
		b	150 (5.91)	165 (6.50)	150 (5.91)	150 (5.91)	185 (7.28)	185 (7.28)	185 (7.28)	257 (10.12)	275 (10.83)	
		c	68 (2.68)	68 (2.68)	68 (2.68)	68 (2.68)	86 (3.39)	86 (3.39)	86 (3.39)	103 (4.06)	103 (4.06)	
		ca	90 (3.54)	92 (3.62)	90 (3.54)	90 (3.54)	110 (4.33)	110 (4.33)	110 (4.33)	155 (6.10)	155 (6.10)	
Mass of Front-Connection • kg (lbs)		0.7 (1.54)   0.95 (2.09)	1.5 (3.3)	0.45 (0.99)   0.6 (1.32)	0.7 (1.54)   0.95 (2.09)	2.0 (4.4)	2.0 (4.4)	2.0 (4.4)	5.7 (12.5)	9.6 (21.12)		

## WS Series Breakers (Continued)

Frame A		100	225	50	100	150	250		400	600	
Model		NF100-CWU	NF225-CWU	NF50-SWU	NF100-SWU	NF-SFW	NF-SJW	NF-HJW	NF-SKW	NF-SLW	
Connection Method	Front Connection	Screw Terminal (F)	Yes	Yes	Yes	Yes	Yes	Yes	Yes	-	-
		Solderless Terminal (Box) (SL)	Yes	-	-	Yes	Yes	Yes	Yes	Yes	Yes
		Busbar Terminal (BAR)	Yes	Yes	Yes	Yes	Yes	Yes	Yes	Yes	Yes
Accessories (*2) Optional	Alarm Switch (AL)		Yes	Yes	Yes	Yes	Yes	Yes	Yes	Yes	Yes
	Auxiliary Switch (AX)		Yes	Yes	Yes	Yes	Yes	Yes	Yes	Yes	Yes
	Shunt Trip (SHT)		Yes	Yes	Yes	Yes	Yes	Yes	Yes	Yes	Yes
	Under-Voltage Trip (UVT)		Yes	Yes	Yes	Yes	Yes	Yes	Yes	Yes	Yes
	Vertical Lead-Wire Terminal Unit (SLT)		Yes	Yes	Yes	Yes	Yes	Yes	Yes	Yes	Yes
External Accessories (*2) (Option)	Mechanical Interlock (MI)		Yes	Yes	Yes	Yes	Yes	Yes	Yes	Yes	Yes
	Handle Lock Device (HL)		Yes	Yes	Yes	Yes	Yes	Yes	Yes	Yes	Yes
	Operating Handle	F	Yes	Yes	Yes	Yes	Yes	Yes	Yes	Yes	Yes
		S	Yes	Yes	Yes	Yes	Yes	Yes	Yes	Yes	Yes
		V	-	Yes	Yes	-	Yes	-	Yes	Yes	Yes
	Insulating Barrier (IB)		Yes	Yes	Yes	Yes	Yes	Yes	Yes	Yes	Yes
	Terminal Cover	Large (TC-L)	Yes	Yes	Yes	Yes	Yes	Yes	Yes	Yes	Yes
		Small (TC-S)	-	- (*4)	-	-	-	-	-	-	-
IEC 35mm Rail Fixture		-	-	Standard	-	-	-	-	-	-	
Automatic Tripping Device		Thermal-magnetic	Thermal-magnetic	Hydraulic-magnetic	Thermal-magnetic	Thermal-magnetic	Thermal-magnetic adjustable	Thermal-magnetic adjustable	Thermal-magnetic	Thermal-magnetic adjustable	
Trip Button		Equipped	Equipped	Equipped	Equipped	Equipped	Equipped	Equipped	Equipped	Equipped	
TÜV Type Approval		Yes	Yes	Yes	Yes	Yes	Yes	Yes	Yes	Yes	

### Notes:

- The trip action characteristics differ between AC and DC for products that are compatible to both AC and DC.
- Specifications for products with a CE mark differ from those for general-purpose products. Details will be available upon request.
- Use two poles among the three poles in the case of three-pole products. In addition, wiring as shown below allows the models of NF100-CWU, NF100-SWU and NF225-CWU to be used for up to 400VDC and the models of NF-SFW, NF-SJW, and NF-HJW to be used for up to 500VDC.

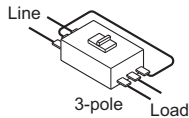

- The standard configuration contains a protection cover and adopts the IP20 (finger protection) structure.
- Products with rated current in parentheses will be produced upon order. Operating characteristics of breakers are different between AC and DC (JIS and IEC only).

## Terminal Covers - Suitable for UL 489 Type Breakers

Part Number (*1)	Stock Item	Applicable Breakers (UL489)
TCL-05SWU2	S	NF50-SWU 2 Pole
TCL-05SWU3	S	NF50-SWU 3 Pole
TCL-1SWU2	S	NF100-SWU, NF100-CWU 2 Pole
TCL-1SWU3	S	NF100-SWU, NF100-CWU 3 Pole
TCL-2SWU3	S	NF225-CWU
TCL-2GSWU3	S	NF-SFW, NF-SJW, NF-HJW
TCL-4SKW	S	NF-SKW
TCL-6SLW	S	NF-SLW

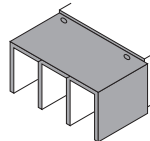

### Note:

- Order 2 units per breaker to protect line and load terminals.

# MCCB Operating Handles

## F-Type Operating Handles

- Mounting type: Circuit Breaker Mount Type  
Structure in which the operating handle and the operating section are mounted on the circuit breaker body
- Panel door open state  
State where both the operating handle and the operating section are attached on the breaker body



F-Type Operating Handle

## V-Type Operating Handle

- Mounting type: Door Mount Type  
Structure in which the operating section is mounted on the circuit breaker body and the operating handle is mounted on the panel door
- Panel door open state  
State where the operating handle is attached on the door and the operating section on the circuit breaker body

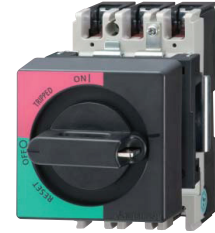

V-Type Operating Handle

## Part Number Structure

### F - 1 S UL 2 LF DR

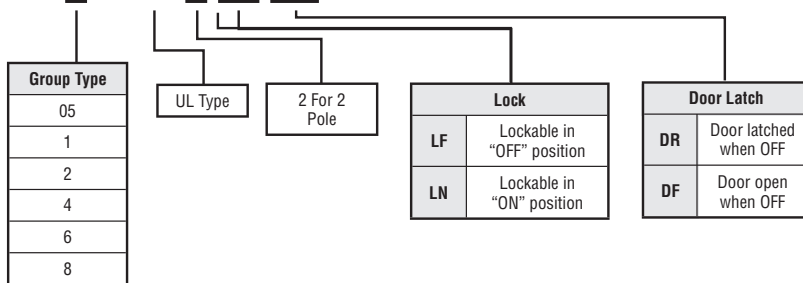

### V - 1 S UL 2

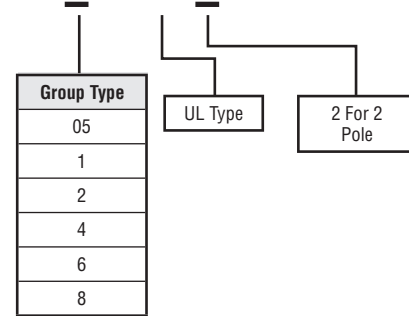

## Handle Family

Model Number	Locking Type	Door Interlock	Applicable Models	Stocked Item
F-05SUL	LF or LN	DR or DF	NF50-SWU 3 POLE	LFDR
F-05SUL2	LF or LN	DR or DF	NF50-SWU 3 POLE	-
F-1SUL	LF or LN	DR or DF	NF100-SWU, NF100-CWU 3 POLE	LFDR
F-1SUL2	LF or LN	DR or DF	NF100-SWU, NF100-CWU 3 POLE	-
F-2SUL	LF or LN	DR or DF	NF225-CWU	-
F-2GSUL	LF or LN	DR or DF	NF-SFW, NF-SJW, NF-HJW	LFDR
F-4SUL	LF or LN	DR or DF	NF-SKW	LFDR
F-6SUL	LF or LN	DR or DF	NF-SLW	LFDR
V-05SUL			NF50-SWU 3 POLE	S
V-1SUL			NF100-SWU, NF100-CWU 3 POLE	S
V-2SUL			NF225-CWU	S
V-2SGUL			NF-SFW, NF-SJW, NF-HJW	S
V-4SUL			NF-SKW	S
V-6SUL			NF-SLW	S

## Extension Kits

Model Number	Applicable Handles	Stocked Item
V-AD3S	V-05 - V-2SG	S
V-AD3L	V-05 - V-2SG	S

# CP30-BA Series Circuit Protectors

For supplementary circuit protection.

## Main Features

- Slim Design - 17.5mm width per pole
- DIN-Rail mountable
- UL1077 / CSA 22.2 recognized
- Choice of 1, 2 or 3 pole variants
- Sizes from 0.1 up to 30A
- 2.5kA interrupt capability - AC or DC

- Multiple different trip speeds available
- Protective cover for terminal screws
- Recessed handle to prevent accidental operation
- 50G shock / 15G vibration withstand ratings
- Option of "Faston" push type terminals for fast connection



Model Number		CP30-BA_P1M_AA			
Stocked Item	1, 2, 3, 5, 7, 10, 15, 20, 30 amp ratings		-		
Number of Poles	1	2	3		
Rated Voltage (V)	AC 250	AC 250	AC 250		
	DC 65	DC 125			
Rated Impulse Voltage Uimp (kV)		2.5			
Rated Current (A)		0.1, 0.25, 0.3, 0.5, 1, 2, 3, 5, 7, 10, 15, 20, 30			
Short Circuit Rating (A)	AC	125V	-		
		240V	2500		
	DC	60V	2500	-	-
		120V	-	2500	-
Operating Characteristics		Instantaneous type (I), Medium speed type (M) (MD), Slow type (S)			
Tripping System		Instantaneous type (I): magnetic only Other type (M, MD, S): hydraulic magnetic			

## Operating Characteristics

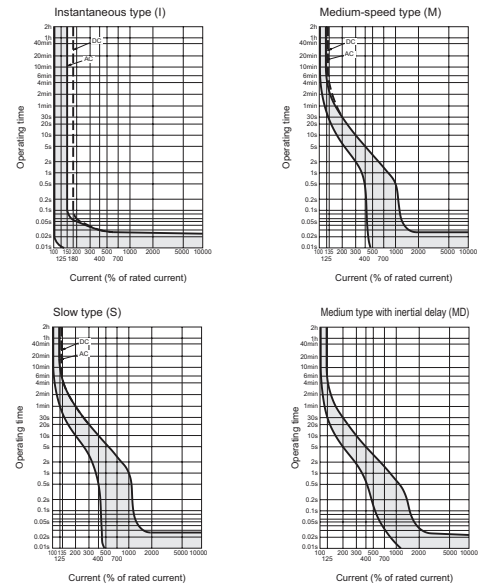

## Dimensions

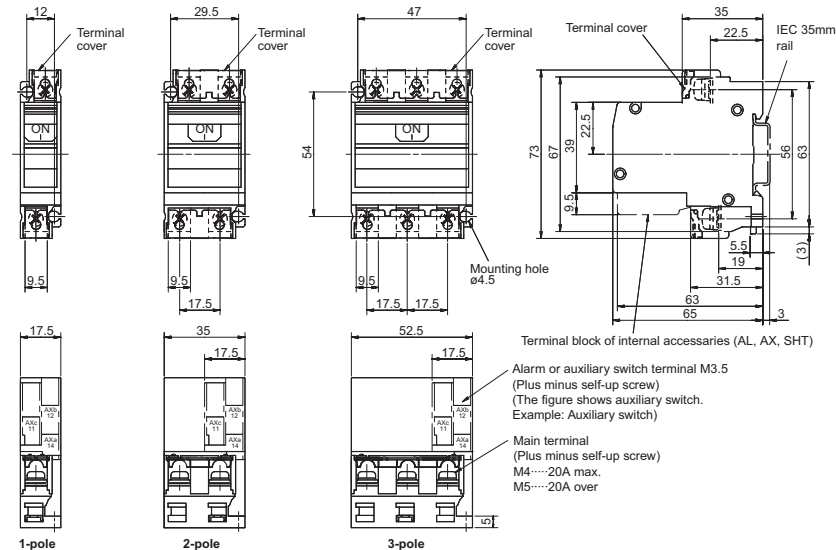

Mounting dimension

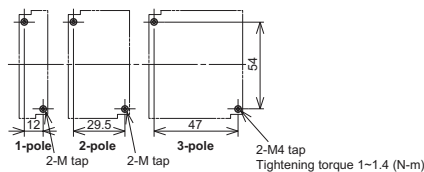

Unit of measure: mm

## Temperature Characteristics

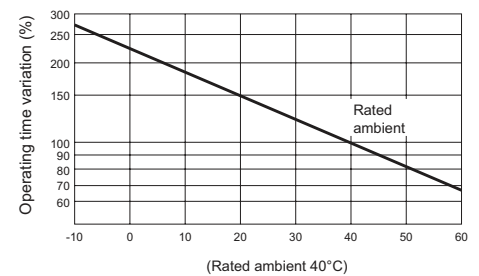

## General Purpose Contactors • S-N Series

The S-N Series was introduced in 1997 beginning with the smaller sizes, by 1999 the S-N Series was a full line Worldwide. The small sizes (S-N10 through S-N48) come standard with Finger Protectors (CX), as is required in Europe. This not only provides more safety, it also keeps the screws in place making losing them a thing of the past.

- S-N Series Contactors are white in color, making the inside of the panels brighter
- A wide variety of sizes and coil voltages are available
- All contactors, except S-N800, carry the UL Recognition Mark
- Smaller contactors (S-N10 ~ S-N80) carry the UL Listing Mark
- Larger contactors (S-N95 ~ S-N800) can be requested with the UL Listing Mark, by specifying UL after the part number (S-N95UL...V)
- All contactors carry the CE Mark

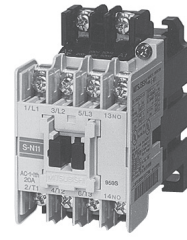

## Motor Protection Relays • TH-N Series

The TH-N overload relays were introduced in 1997 along with the smaller size S-N Series contactors. The smaller TH-N Series (TH-N12, TH-N18 & TH-N20) have Finger Protectors (CX) to match up with the S-N Series contactors to which they connect.

- Easy maintenance and inspection
- Easily switch between automatic and manual reset
- Simple top mounted dial adjustment
- Easily identifiable trip mechanism
- All are available as contactor mount or as separate mounted units

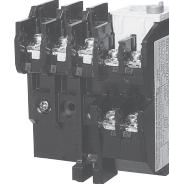

## Definite Purpose Contactors

The DU Series are designed for DC Circuits (with AC Coils) and DC Motor Control. The S-U Series are compact horsepower rated units used in compressors, blowers, fans and pump motors. The S-N Series Compact 3-Pole units, S-N18, S-N38 and S-N48, were designed for machine control panels with limited space available. The DC Interface Contactors and Modules were specially designed to be directly driven by the transistor output of a Programmable Logic Controller.

### DU Series

- Wide range of both AC and DC coiled units available
- Compact design
- High break capacity
- Double break contacts

### S-U Series

- DIN rail mountable
- Available with or without auxiliary contact block
- Available as a reverser

### S-N Series

- Din rail mountable
- Designed for machine control panels with limited space available

### DC Interface Contactors and Modules

- Specially designed to be directly driven by the transistor output of a Programmable Logic Controller

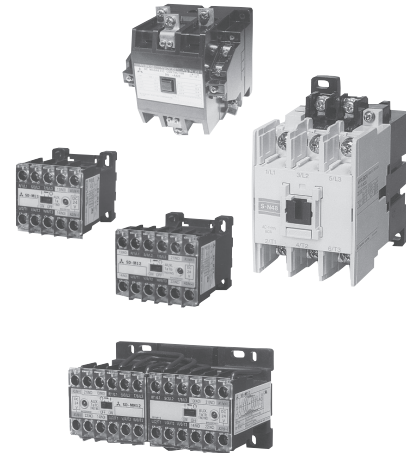

## Contactors Relays • SR-N Series

The SR-N Series are specially designed for use in low voltage control circuit applications.

- High reliability
- Long life
- DIN rail mountable
- Easy wiring
- Accessories common

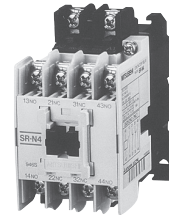

## Vacuum Contactors • SH-V Series

The SH-V Series are medium voltage contactors specially designed for use in mining, pumping, sawing and other applications where voltage above 1500 VAC.

- Rated to 1500V (up to 3300V using optional barrier)
- 4 non-reversing sizes from which to choose
- 3 reversing sizes

